

IS SERIES

Industrial Strip

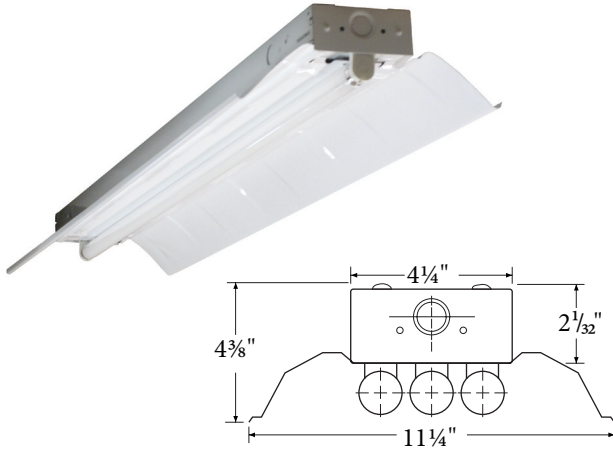

DESIGN

The IS Series Industrial Strip is designed as a high quality general purpose fixture with a symmetrical reflector¹. It is ideal for simple task and area lighting applications and industrial environments.

ACCESSORIES

Order as separate line item

6' 16/3 CORD W/ NEMA PLUG
C1 (120V)
C2 (277V)
C4 (480V)

T8 EMERGENCY BALLAST
EB5 (500 LUMEN)
EB7 (700 LUMEN)
EB14 (1400 LUMEN)
EB30 (3000 LUMEN)

MOTION SENSOR
WOC (120/347V)
WOC1 (480V)

WIRE GUARD
ISWG4 (4')

WIRING HARNESS
WH34 (3 WIRE, 4')
WH44 (4 WIRE, 4')
WH54 (5 WIRE, 4')

ALIGNER CLIP
HLFACLIP

PHOTOMETRICS

IES INDOOR REPORT
PHOTOMETRIC FILENAME : B2322IES
POLAR GRAPH

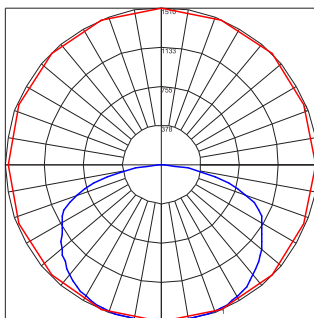

Maximum Candela = 1510 Located At Horizontal Angle = 90, Vertical Angle = 7.5
1 - Vertical Plane Through Horizontal Angles (90 = 270) (Through Max. Cd.)
2 - Horizontal Plane Through Vertical Angle (7.5) (Through Max. Cd.)

1.800.225.0727

ORDERING INFORMATION

Description	Part Number ¹
1L 17W T8 120/277V	IS117 (A)D(B)
1L 25W T8 120/277V	IS125 (A)D(B)
1L 32W T8 120/277V	IS132 (A)D(B)
1L 54W T5HO 120/277V	IS154 (A)D(B)
2L 17W T8 120/277V	IS217 (A)D(B)
2L 25W T8 120/277V	IS225 (A)D(B)
2L 32W T8 120/277V	IS232 (A)D(B)
2L 54W T5HO 120/277V	IS254 (A)D(B)

Option Codes

(A) Housing

U - Uplight
S - Solid
UM - Mirro Uplight
SM - Solid Mirro

(B) Options

Blank - None
10RS - ≤10% THD, Rapid Start
P - Program Start
20 - ≤20% THD

MOUNTING

2 Sets of each are provided per order



(3)S HOOKS AND
CHAIN SET
10JC



TONG HANGER
THE (END MOUNT)
THS (SIDE MOUNT)



AIRCRAFT CABLE WITH
12" ARMS
G10 (10')
G15 (15')
G20 (20')

TECHNICAL INFORMATION

Fixture housing, lamp holder brackets, end sections, and channel cover are constructed of heavy gauge die-formed steel. Sturdy embossed reflectors effectively direct and control light. ETL listed. Suitable for damp locations. Ballasts are solid state electronic. Ballasts and lamp holders are replaceable without removing from ceiling. Can be mounted as single fixture or in a continuous row. All reflective surfaces are finished with a high reflectance, lighting fixture white polyester powder.

Notes: 1-Asymmetrical Reflector version is available. See Strips Complete Nomenclature page for ordering information.

WWW.TECLIGHTUSA.COM

309

All specifications are subject to change without notice. Please refer to www.techlightusa.com for the most current information.